



BUILDING A FIRE
AND A LITTLE BIT ABOUT RUMFORD AND HIS FIREPLACES



SUPERIORCLAY.COM

RUMFORD FIREPLACE



Count Rumford, for whom the fireplace was named, was born Benjamin Thompson in Woburn, Massachusetts in 1753. He spent much of his life as a high ranking official of the Bavarian government where he received his title, Count Rumford. Rumford is primarily known for the work he did on the nature of heat. Rumford wrote two essays detailing his improvements on fireplaces, one in 1795 and the other in 1798. He was well known and widely read in his lifetime and almost immediately in the 1790's his "Rumford Fireplace" became state of the art worldwide and remained so until wood burning fireplaces went out of fashion (in favor of coal and later, gas fireplaces) in the 1850's.

Rumford thought that fireplaces should be a lot smaller than they were in England in the 18th century. They wasted too much heat up the chimney and pulled too much cold air into the room.

He also knew from his study of heat that if the fireplace is shallow (ideally one third as deep as it is wide) and the coving (or sides) are angled a maximum of 135 degrees to the back wall, the fireplace would reflect more heat into the room.

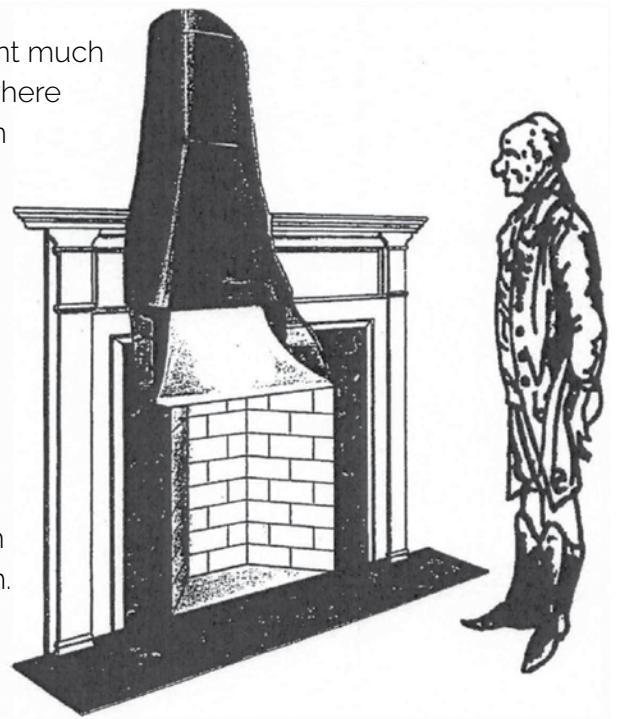

INSTRUCTIONS

RUMFORD FIREPLACES

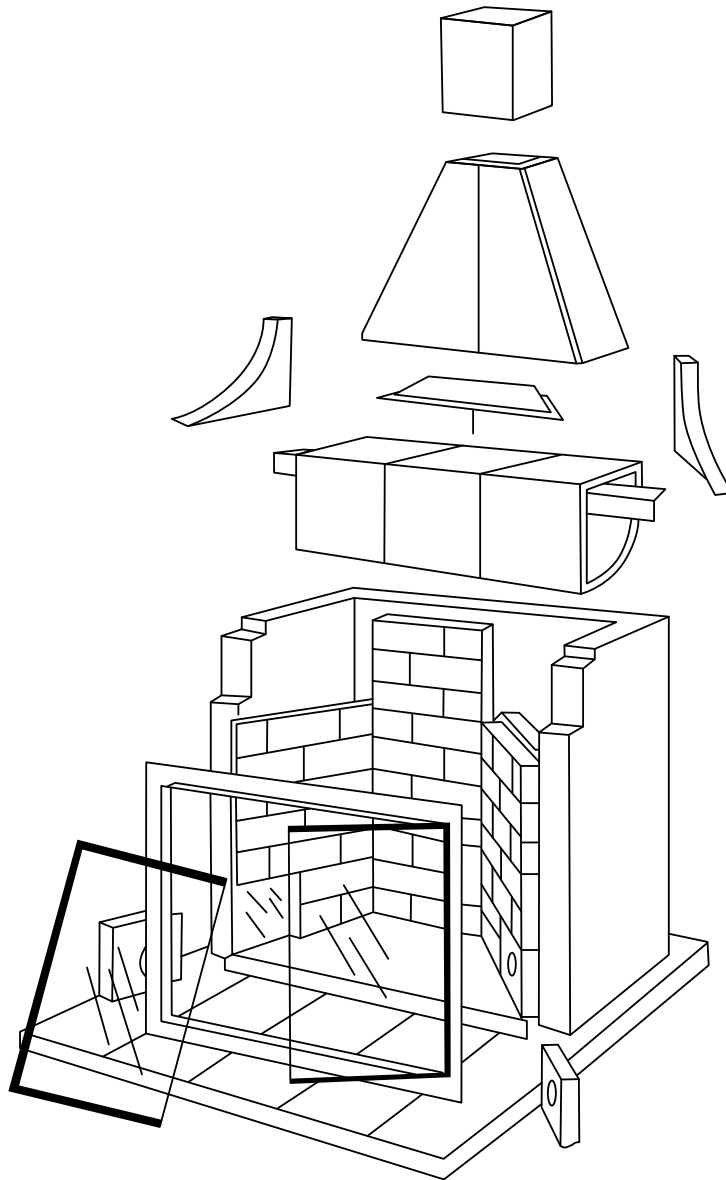

Please leave the cover and four attached pages on Rumfords and fire building for the homeowner.

RUMFORD FIREPLACE PLANS USING THROAT SECTIONS

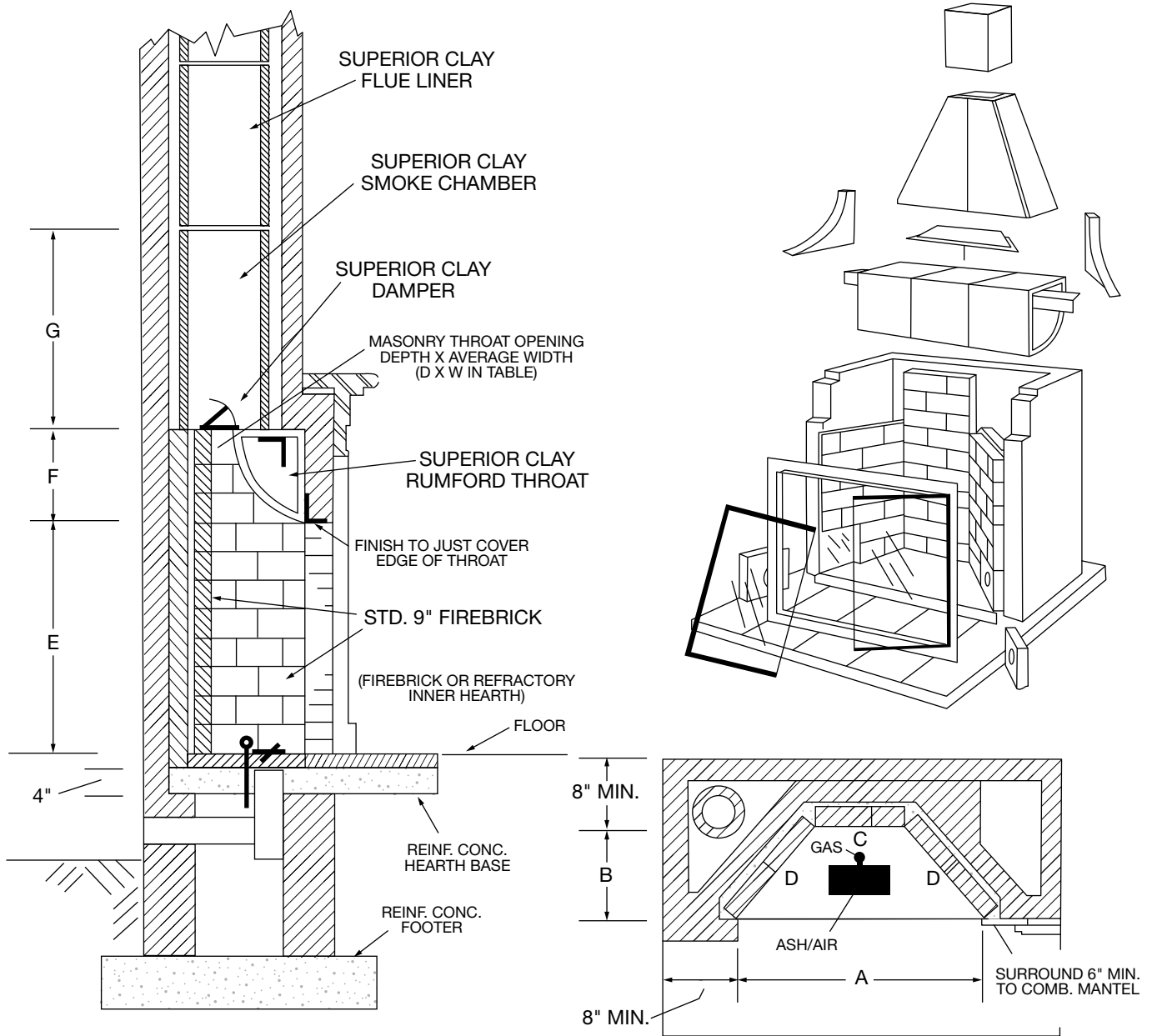

FIREPLACE	THROAT	DAMPER SIZE	SMOKE CHAMBER	FLUE	OTHER DIMENSIONS						
SIZE	(D x W)		(BASE x G)	SIZE	A	B	C	D	E	F	G
36" W	20" x 4"	9" x 24"	13" x 30" x 19"	13" x 13"	36"	14"	13.5"	18"	32"-36"	13.5"	19"
42" W	23.5" x 4.5"	9" x 30"	13" x 34" x 19"	13" x 18"	42"	15"	15"	21"	38"-42"	13.5"	19"
48" W	27.5" x 5"	9" x 30"	16" x 34" x 19"	16" x 20"	48"	16"	18"	22.5"	42"-48"	13.5"	19"
60" W	10" x 27"	10" x 42"	20" x 50" x 30"	20" x 20"	60"	20"	22.5"	27"	45"-54"	13.5"	30"
72" W	10" x 34"	10" x 48"	24" x 57" x 30"	24" x 24"	72"	24"	27"	31.5"	45"-60"	13.5"	30"

Note: Dimensions can be modified. Call a technician at Superior Clay 800.848.6166.

RUMFORD FIREPLACE PLANS

USING 1 PIECE RUMFORD THROAT

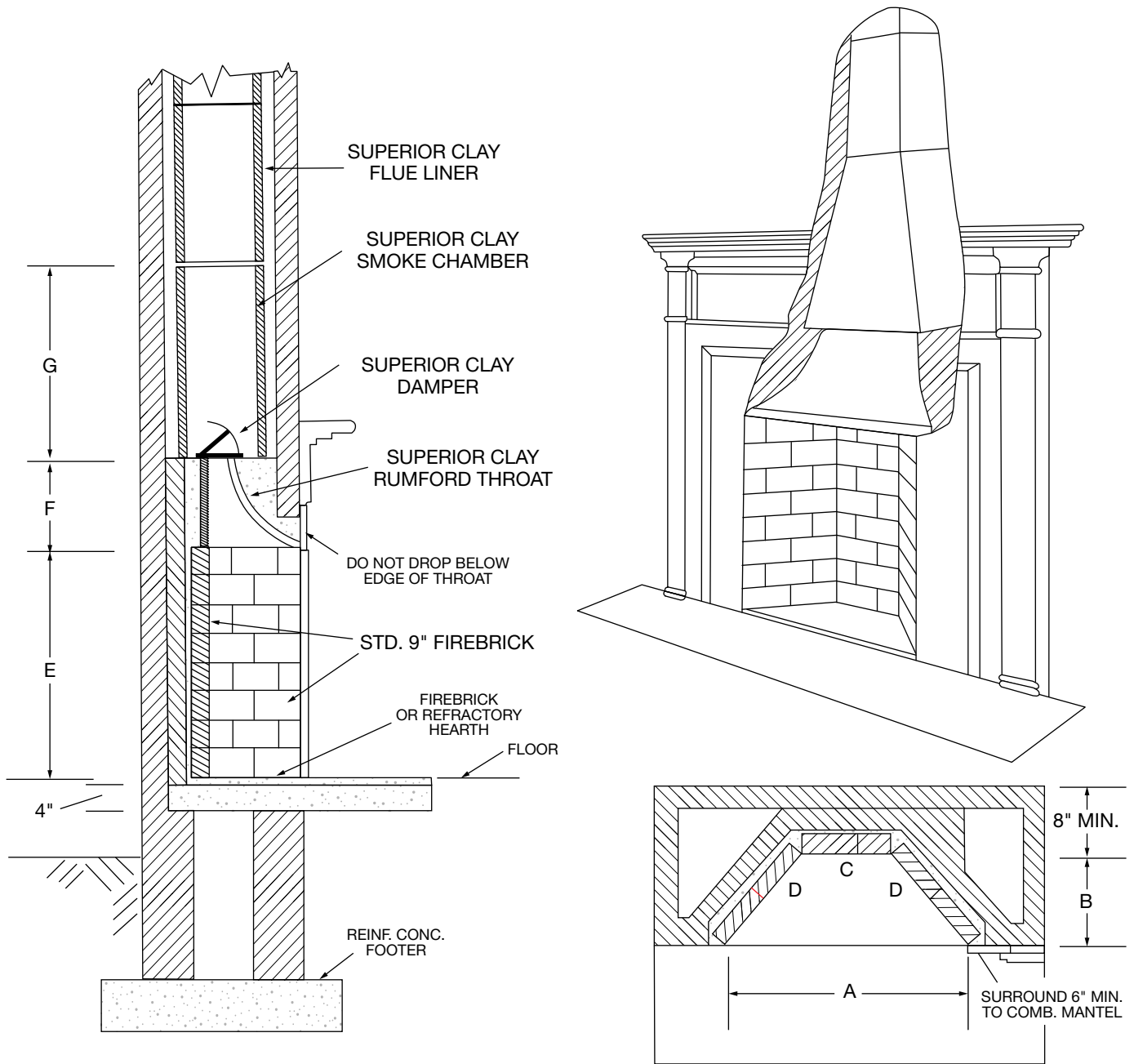

FIREPLACE	THROAT	DAMPER SIZE	SMOKE CHAMBER	FLUE	OTHER DIMENSIONS						
SIZE	(A x F)	FRAME	(BASE x G)	TILE	A	B	C	D	E	F	G
24" W	24" x 12"	6" x 22"	8.5" x 24" x 19"	8.5" x 13"	24"	12"	13.5"	13.5"	24"-28"	12"	19"
30" W	30" x 12"	9" x 24"	13" x 30" x 19"	13" x 13"	30"	12"	13.5"	15"	28"-32"	12"	19"
36" W	36" x 14"	9" x 24"	13" x 30" x 19"	13" x 13"	36"	14"	13.5"	18"	32"-38"	14"	19"
42" W	42" x 15"	9" x 30"	13" x 36" x 19"	13" x 18"	42"	15"	15"	21"	38"-42"	15"	19"
48" W	48" x 16"	9" x 30"	16" x 36" x 19"	16" x 20"	48"	16"	18"	22.5"	42"-48"	16"	19"

STEP 1

FOUNDATION

A solid masonry hearth base 4" thick should be supported on an adequate masonry foundation.

WIDTH

- For the 24" Rumford the hearth base should be at least 4' -0" wide.
- For the 30" - 4'-6" wide
- For the 36" - 5'-0" wide
- For the 42" - 5'-6" wide
- For the 48" - 6'-0" wide
- For the 60" - 7' wide
- For the 72" - 8' wide

DEPTH

- For the 24" Rumford the hearth base should be at least 3'-4" deep
- For the 30" - 3'-8" deep
- For the 36" - 4'-0" deep
- For the 42" - 4'-0" deep
- For the 48" - 4'-4" deep
- For the 60" - 4'-8" deep
- For the 72" - 5'-0" deep

From front to back the hearth base must be deep enough to support the firebox and chimney plus a hearth extension at least 20" out in front of the fireplace opening. In houses with rooms or crawl spaces below the fireplace, this hearth extension is usually cantilevered and constructed of self-supporting reinforced concrete or "corbel slabs" supported by a masonry stem wall the same size as the wall surrounding the firebox. The floor joists are headed off 20" in front of the fireplace opening and as wide as the hearth base. Usually the face of the roughed in fireplace, without surround, is flush with the inside surface of the wall. The depth of the foundation needed to support the chimney depends on the construction materials and design and usually must be more than the minimum dimensions below for chimneys built on the outside of exterior frame walls. If in doubt skip ahead to Step 10 on chimneys.

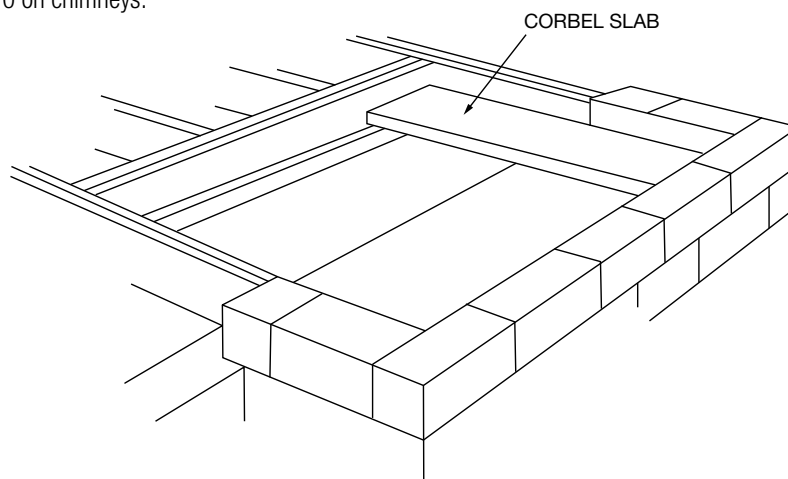

This hearth base should be 3" below finish hearth or floor level to allow for a firebrick inner hearth and a brick hearth extension. A gas line stub out for a gas starter and an ash-dump or combination outside air intake/ash dump can be incorporated in the inner hearth if desired. For larger fireplaces in tight homes two outside air intakes may be needed.

STEP 2

FRAMING

In general, combustible materials should be kept 2" away from the outside of a masonry fireplace or chimney. If the chimney is to be built on the outside of a frame house, the rough opening in the combustible wall should be 4" wider than the masonry with the header 3'-0" above the top of the fireplace opening. For a 48" tall fireplace, for example, the combustible header should be about 7'-0" above the floor or hearth.

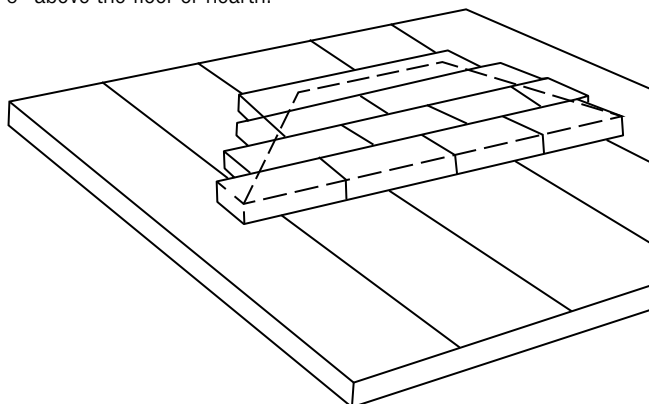

STEP 3

INNER HEARTH

Lay firebrick on the masonry hearth base, using Heat Stop refractory mortar to make maximum of 1/4" to meet code between the firebrick. The firebrick inner hearth should be just big enough so the firebrick firebox can be laid on top of it.



STEP
4

FIREBOX



Build the Rumford firebox using standard residential duty firebrick or better. Use Heat Stop refractory mortar. Fill- any voids and wash the firebox with a sponge and plain water. Rumford fireplaces are usually about as tall as they are wide but you can vary the height by the number of firebrick courses laid. Before starting the firebox lay out the first course of firebrick and double check all the firebox dimensions on the plan.

If you are installing a Rumford kit with a glass door, set, level and brace the steel frame for the glass door provided with the core kit on the hearth where you want the rough firebrick opening to be - usually flush with the inside surface of the wall.

Use the glass door frame as a template laying the firebrick so that the firebricks forming the front edge of the covings just meet the back inside corner of the door frame.

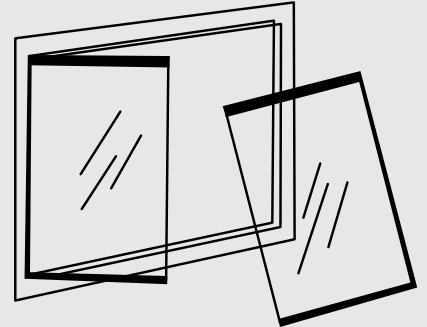

For certified units, the door frame ensures the correct fireplace opening size which is an important part of the certification. You are not permitted to modify it. The door frame is designed to be just the right height if you use standard firebrick and refractory mortar with minimum 1/16th and maximum 1/4 inch joints.

The clay 9" x 9" wolf head air intake blocks should be laid like a double firebrick in the bottom forward corner of each coving. Looking at the fireplace, the wolf head on the left should be facing back in a more or less level attitude and the one on the right should be facing up and back as if howling at the moon. Leave a channel in the backup brick to allow outside air to be ducted in behind the wolf head blocks

STEP
5

BACKUP BLOCK

The firebrick should be backed up with solid masonry (75% or more solid) so that the firebox walls are at least 8" thick.

Lay 4" x 8"x 16" solid concrete block ("seventy-five percenters") on the concrete hearth base to back up the firebox. Weave the backup block together at the corners for strength and fill the space between the block and the firebrick solid with ordinary mortar.

If you are using throat sections:

When you get to the top of the opening, continue to lay block on each side of the firebox to carry the steel angle which supports the throat sections. These block bearing surfaces should be perpendicular to the face of the fireplace opening, 12.5" above the top of the fireplace opening and 3" behind the front edge of the firebrick on each side.

BLOCK BEARING SURFACE

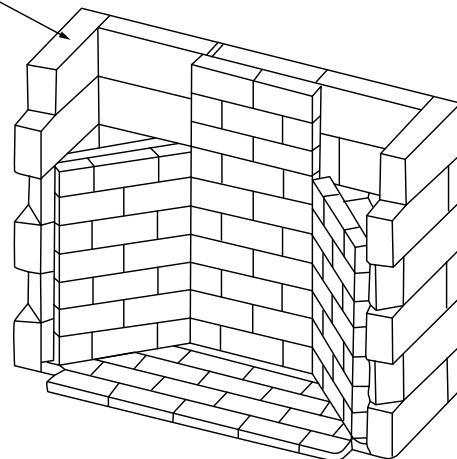

STEP 6

SET THE THROAT

If you are using throat sections:

Thread the throat sections on the steel angle and set the throat, as a unit, on the two concrete block bearing surfaces 3" back and 12.5" above the top of the fireplace opening. If you are working alone you can rest one end of the angle lintel on the block and thread the throat sections on the other end one at a time. Don't try to mortar the throat sections together before setting the throat. It's best to set the throat dry and then adjust the individual throat sections to a temporary two by four guide nailed across the top of the opening. A length of rebar mortared inside the throat sections at the bottom can help stabilize them. Work refractory mortar into the curved joint inside the firebox after the throat is in place. Ordinary mortar is fine for the front and top joints between the throat sections as you lay the surrounding masonry.

Set the "right" and "left" coving extension tiles to meet the curved throat. Extend the fireback 13.5" higher to the top of the throat sections.

Finish the covings with firebrick to meet the extended fireback to the top of the throat sections - 13.5" above the fireplace opening. fill in the spaces between the firebrick and the throat sections and between the throat sections with refractory mortar.

For 60 and 72 inch Rumford Fireplace, maintain 10 inch throat opening to allow for flow through damper.

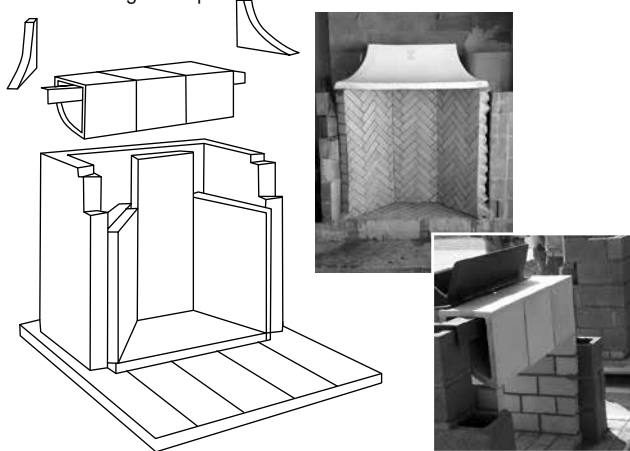

If you are using the one piece throat: Set curved Rumford throat in Heat Stop refractory mortar on top of firebox.

Masonry Throat Opening Size Critical

The most important dimension at this stage is the depth of the masonry throat opening.

The proper depth should be:

- 36" Rumford - 4" front to back
- 42" Rumford - 4.5" front to back
- 48" Rumford - 5" front to back
- 60" Rumford - 10" front to back
- 72" Rumford - 10" front to back

STEP 7

CREATE A PLATFORM



Lay the surrounding masonry up to the top of the one piece throat or throat sections and the fire back so that a flat platform is created to set the damper and smoke chamber.

SET THE RUMFORD DAMPER

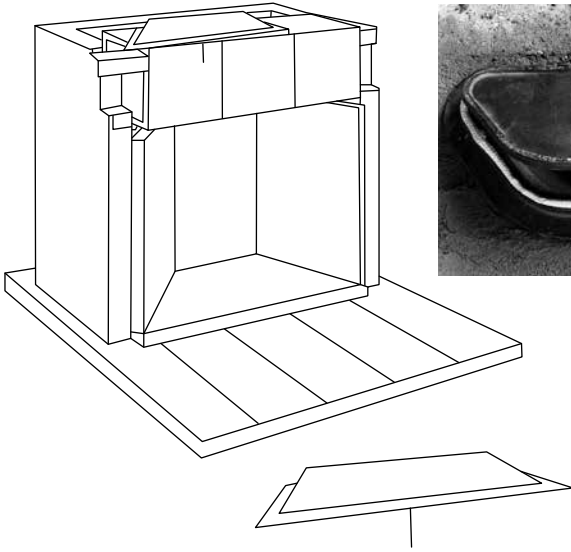

Set the Rumford damper over the masonry throat opening using refractory mortar. Make sure the damper is set high enough that the hinge pins don't hit the throat. There should be a pocket under each hinge pin allowing them to move freely. Check that the valve operates freely.

Installation of VESTAL or dome style dampers and modified handles with RUMFORD throat sections.

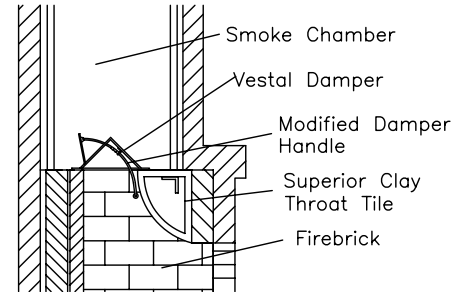

When setting the damper, be sure that the top back edge of the curved throat tile is aligned with the front inner edge of the throat opening of the damper. Check that the valve operates freely

Rumford Cast Iron Damper with Gasket

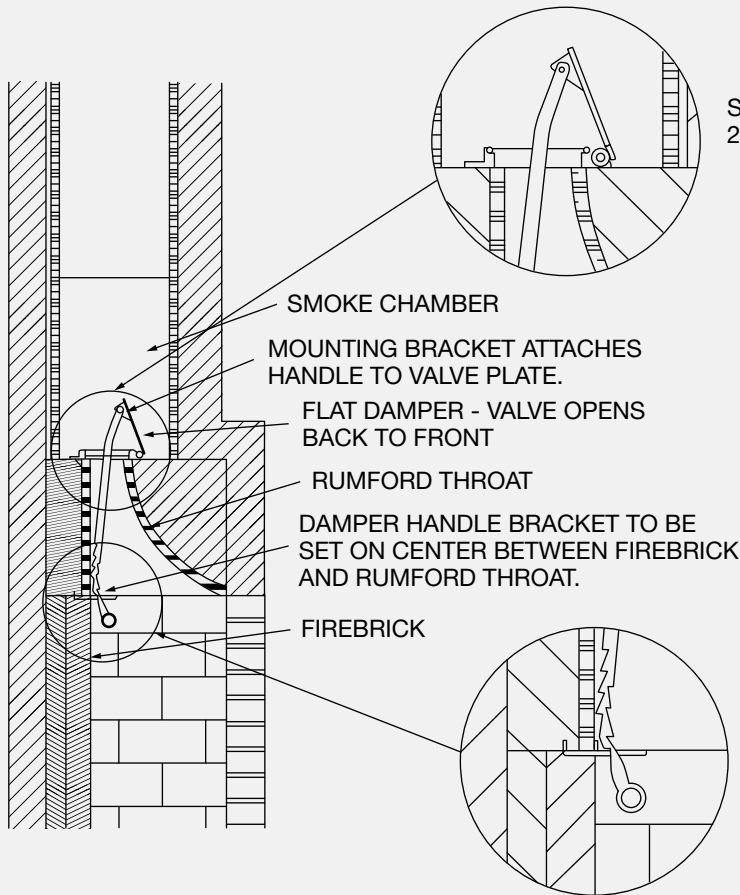

See Installation Notes 2, 4 & 5

DAMPER INSTALLATION

- ① Center damper handle bracket on the top of the back wall of firebox and set Rumford Throat.
- ② Align damper over throat opening of Rumford Throat.
- ③ Slide handle through damper handle bracket and attach to valve plate.
- ④ Set smoke chamber.
- ⑤ Check damper operation to make sure damper opens freely within the smoke chamber cavity.

See Installation Notes 1, 3 & 5



STEP
9

SMOKE CHAMBER

Set the vitrified clay smoke chamber in refractory mortar over the damper on the platform at the top of the throat sections. The smoke chamber can be shifted to one side or the other, forward or backward or "leaned" to line up with the chimney as long as the damper valve opens without striking the inside of the smoke chamber. Fill the joints between the sections of the smoke chamber with refractory mortar. Lay up the surrounding masonry at least 4 inches thick around the smoke chamber so that the total thickness through the smoke chamber wall is at least 6".



STEP
10

BUILD CHIMNEY



Interior chimneys are 4" min. larger outside in all four directions than the flue they contain. A chimney containing a 12"x 12" clay flue liner must be at least 20" by 20". Combustible materials must be kept at least 2" away from the chimney walls.

Exterior chimneys usually extend an extra 4" away from the exterior combustible wall of the house to accommodate the clay flue liner and the required 1" air space to the siding and still be able to close the gap with whole and half bricks.

By code the chimney must extend at least three feet above the roof and two feet above any part of the roof within ten feet. Cast in place or use a pre-cast concrete chimney cap with a drip edge and caulk the joint between the cap and the top flue liner with a silicone sealant. Flues can be mitre cut and angled up to 30° from vertical to get around headers, framing and other fireplaces.

In Seismic Zones 2, 3 and 4 place a #4 steel reinforcing bar in each corner of the chimney between the flue liner and the surrounding masonry and grout the space solid. To allow the flue liners a little room to expand without cracking the exterior masonry we recommend wrapping the flues with 1/8" ceramic paper "socks" before placing the grout. Tie the surrounding masonry horizontally every 18" with steel tie ladders in the bed joints. Exterior chimneys must be anchored at each floor and roof.

Continue the brick surround covering the front of the throat and at least 4" or masonry thick across the top of the throat tiles, stepping back, if necessary, to accommodate a combustible frame header. The surround (the area at least 6" wide around the fireplace opening) can be finished with brick, stone, tile, terra cotta, slate, marble - almost any decorative masonry material. 100 years ago fireplace surrounds were often finished with ordinary plaster and sometimes painted black. The surround also covers the flange of the Rumford door frame (if you are installing a door) to minimize it visually, but be sure to keep the surround material 1/8" away from the door frame so that when the frame gets hot and expands it won't crack the surround.

There is really no need to use the surround to make the fireplace deeper. A brick or stone surround is OK. It may block some of the radiant heat. If tile or other relatively thin material is used for the surround, consider setting it on a backing of cement board or a scratch coat of mortar or plaster over expanded metal lath.

At the top of the fireplace opening make the surround just low enough to cover the edge of the throat. You can use a steel angle to support a brick or stone header, but set the angle right at the throat and maintain the curved line of the streamlined throat. This curve is like the leading edge of an airplane wing. Don't ruin the air flow by dropping a header several inches below the opening.

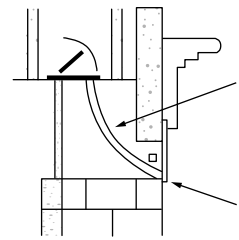
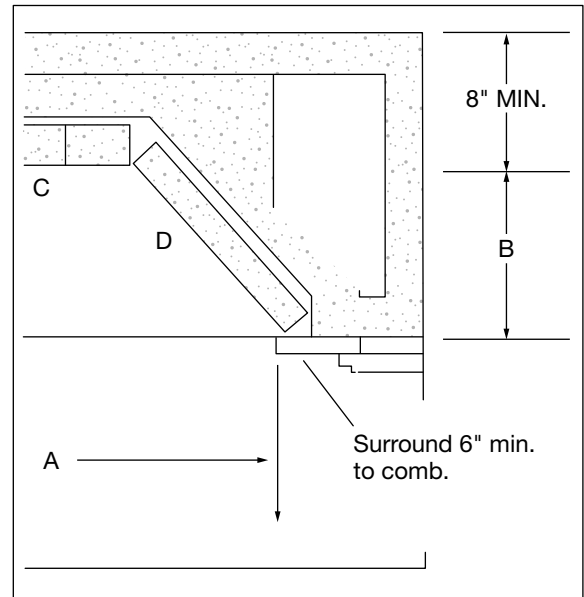

MAKING RUMFORD FIREPLACES DEEPER

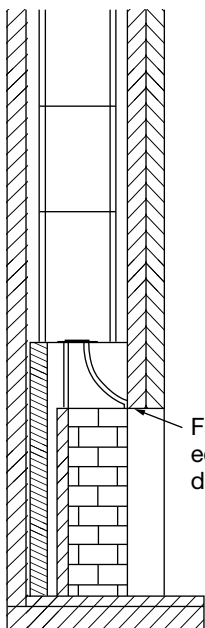

Count Rumford and Jim Buckley would argue that you should never make fireplaces deeper than we show on our chart on page 4 because this is the approximate depth Count Rumford determined, through experimentation, to provide optimum transfer of radiant heat. As Jim would say, "It's like putting a lawn mower engine in your Jaguar."

However, if you have to have a deeper firebox, as long as you bring the face straight into the room and don't drop below the curved throat with your lintel, the fireplace will work fine.

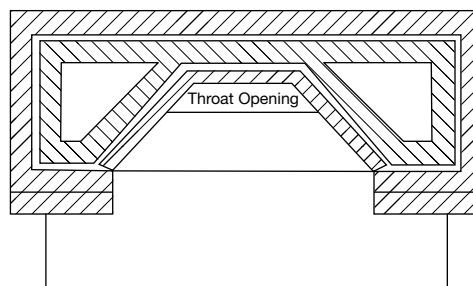

ARCHED FRONTS

For arched fronts the same rule applies. Don't drop the lintel down below the curved throat, as this creates turbulence. Put the high point of the arch at the same elevation as the leading edge of the curved throat.

Facing just to cover edge of throat. Do not drop below this point.

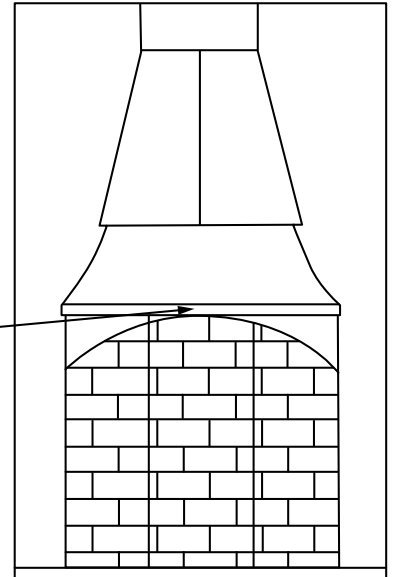

GLASS DOOR

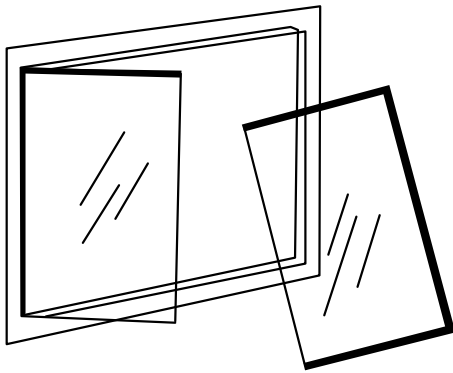

Rumford fireplaces don't need glass doors to burn efficiently and cleanly. In fact the glass blocks a lot of the radiant heat. Doors can, however, be useful to close off a dying fire or when you're not using the fireplace. The Washington State Indoor Air Quality code requires fireplaces to have glass doors so we tested the Rumfords both with and without doors and we provide glass doors as part of our Washington Certified Core. Our doors have a minimal frame that is used as a template to facilitate construction of the firebox and when finished reveals only a one inch by 1/8th inch flange. The doors also have a minimal frame that reduces the opening by only one inch top, bottom and sides. And the glass doors are easily removable and/or can be exchanged for screen doors (optional) during a fire. Doors with tempered glass should be open during a fire or they may shatter.

For more details, photos and information, visit our website at rumford.com

ADD A CHIMNEY TOP

Finish off your new Rumford with a beautiful handmade chimney top. Over 40 styles to choose from.

VISIT SUPERIORCLAY.COM FOR MORE STYLES.



STACKED RUMFORD FIREPLACES

Building fireplaces that share a chimney and foundation is an economical way to get a second fireplace. Adding flues to vent other appliances further takes advantage of the chimney stack.

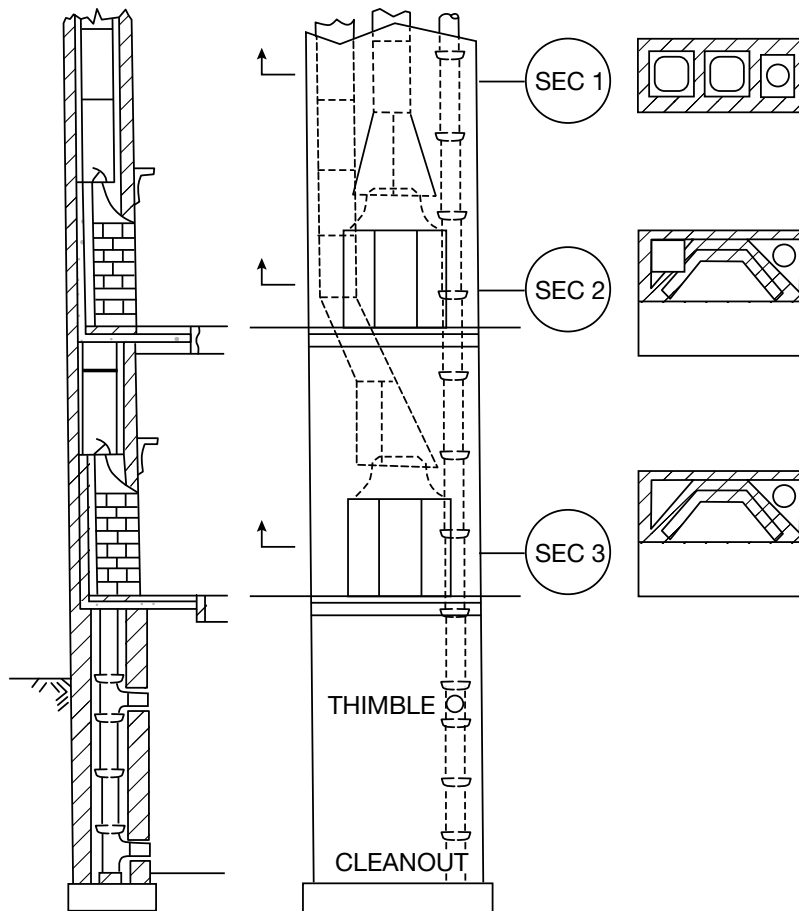

HERRINGBONE FIREBOXES

Herringbone fireplace fireboxes built by Superior Clay Corporation using brick with the 9" by 11¼" face showing in a vertical herringbone pattern. The fireboxes are shipped in sections (two covings and the fireback) and are easily erected at the job site. The pre-made fireboxes save masons time and aggravation and allow them to build beautiful herringbone fireboxes.

Superior Clay Herringbone Firebox walls are pre-built at the factory and shipped ready to be set in place during construction of the fireplace. Supply us with the dimensions required and we'll build your Herringbone Firebox. Other Brick Patterns are also available.



STEP-BY-STEP INSTRUCTIONS

STEP 1

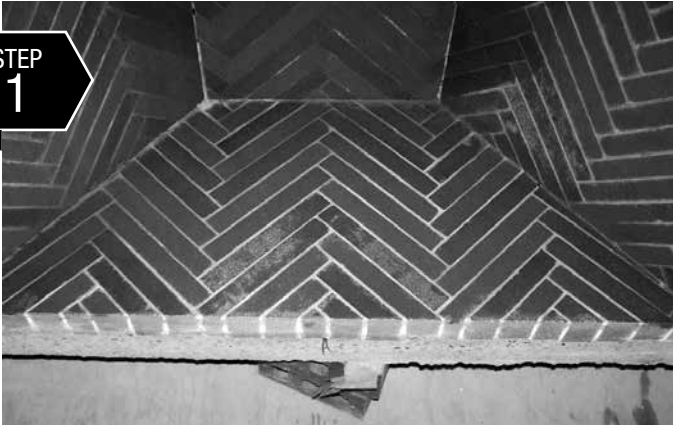

The mason lays the inner hearth, level and centered, in a bed of mortar.

STEP 2

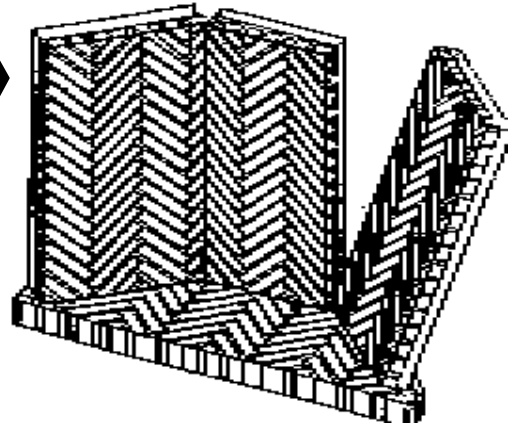

The next day, the coverings and the fireback are set in place, in the refractory mortar provided, on the hearth. They are temporarily supported with concrete blocks or lumber.

STEP 3

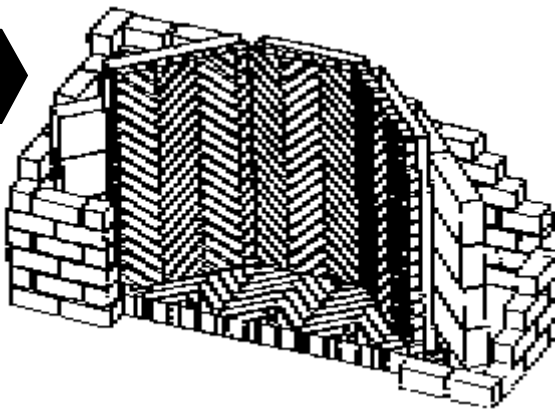

A solid masonry backing wall at least four inches thick is built to permanently support the firebox.

STEP 4

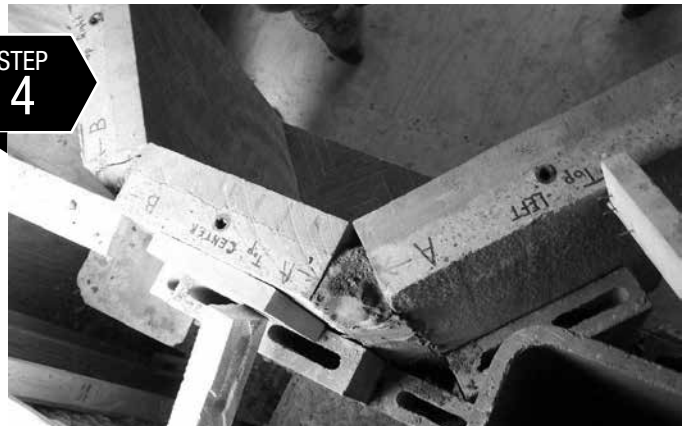

Refractory mortar is used to fill any cracks between the four pieces of the firebox and the firebox is washed with clean water.

STEP 5



Now the firebox is ready to be treated like any other - carefully - until the solid masonry has cured.

STEP 6



Set the Rumford throat.

STEP 7



Continue building the Rumford fireplace and chimney.

RUMFORD FIREPLACES

BALANCING THE VENTILATION SYSTEM

In any house the warm air tends to rise and find a way out somewhere high in the house. In other words the whole house acts like a chimney. In most houses there is a neutral pressure level about half way between the ground floor and the roof. Everything above that level is positively pressurized and air will leak out of any open windows or holes, while below the neutral pressure level the house is negatively pressurized and air will leak into the house through any openings. In old leaky houses the negative pressure rarely exceeds about eight pascals, which is about the difference in pressure in ten feet of altitude - not much. Furnaces and fireplaces usually do fine pulling against a negative pressure of up to eight pascals.

Chimney height and location matter. If the chimney is not as tall as the house or is on an outside wall so the air in the chimney is cold, the house may "draw" better than the chimney. When possible, locate chimneys inside the exterior walls of the house and build them taller than the highest part of the house.

Modern houses tend to be tightly built, wrapped, sealed and caulked. They also tend to be full of powerful kitchen and bathroom exhaust fans. So the negative pressure in the lower areas of a new house can sometimes far exceed eight pascals.

For a fireplace to draw well, especially as the fire dies down and little heat is being produced to overcome negative pressure, you may have to let in some makeup air near the fireplace or somewhere low in the house. Usually the six square inch combustion air kits designed to be built into the firebox are not big enough. They can lead to other problems like creosote or ash smells and enough turbulence to cause the fireplace to smoke. Better to open a window or add makeup air to a cold air return in the heating system or install an air-to-air heat exchanger in the mechanical, utility or laundry room.

The engineering can be complicated but it's easy to see if you have the indoor pressure under control. Use a stick of incense, or something that smokes, and hold it up in the throat of the fireplace to see if the smoke goes up the chimney. If it does, great - no problem. But if the smoke blows down and out into the room, indicating there is a down draft in the chimney, that means the room is too negatively pressurized and the easiest way for makeup air to replace the air being lost up high somewhere in the house is down the chimney.

Note: Once in a while we have discovered a very tight house that doesn't leak in or out so there is no down draft in the chimney, but when a fire is burning the fireplace creates the negative pressure that won't allow it to draw properly. In such a case (if the fireplace smokes when no down draft is observed without a fire burning) first open a window or door and build a fire in the fireplace. Then slowly close the door or window and go through all the pressure sleuthing smoke tests.

Find a way to neutralize the down draft. Open a window or door low in the house. Turn off fans and the furnace. Close the skylight and upstairs windows. Do these things one at a time and give the air enough time (a couple of minutes) to turn around and reverse itself. See what it takes to control the pressure so that there is no down draft in the chimney even before you light a fire in the fireplace. The specific things you try depend on your house but always think of reducing the air escaping high in the house and increasing the air coming into the house on the lower floors. The cold air return in the room with the fireplace may need balancing, it may make a difference which window you open or close, especially in a breeze. But you want to let more air in low in the house so when you open a window, check with the incense smoke to see if air is actually flowing into the house.

Once you've closed off as many leaks as you can high in the house and found out where and how much makeup air you have to let in low in the house, then you can think of a permanent solution like makeup air into the cold air return or an air-to-air heat exchanger that might be more palatable than opening a window.

BUILDING A FIRE IN YOUR RUMFORD FIREPLACE

BY JIM BUCKLEY

Use well seasoned hardwood. Any wood fire needs three to five logs to maintain combustion. Fewer, bigger logs can be used if the wood is well seasoned. Many of our Rumford fireplaces are quite large, but even in our smallest Rumford, 20" logs will fit standing up on end.

BUILD TALL TEPEE FIRES: Rumfords are tall fireplaces so take advantage by building tall fires. Stand the logs on end against the fireback, tepee style. This raises the fire and more nearly fills the tall Rumford firebox with fire to maximize the radiant heat output. A tall fire burns cleaner. By keeping the smoke and products of combustion in the flame and hot longer, more of it burns up and the fireplace produces little smoke and little pollution.

LAYING THE FIRE: Pin a sheet of newspaper against the fireback with some long sticks of kindling. Surround the newspaper with at least six or seven pieces of kindling 16 to 20" long and about 1" in diameter. Lean four or five logs on end against this cylinder of kindling, all pointing up toward the center of the throat, like a tepee. No grate is need with a Buckley rumford fireplace. You can build a fire right on the hearth. In fact the fire burns cleaner if you do.

OPEN THE DAMPER AND LIGHT THE FIRE: Light a sheet of newspaper on top of the fire to heat up the flue and get the air in it going up. Light the newspaper inside the bundle of kindling at the top. The flame at the top of the fire bums up the smoke. As the fire burns down through the kindling adjust the logs and add more as needed standing on end and leaning against the fire or the fireback.

You might have to add more newspaper on top of the fire or even poke some under the kindling to get it going. Keep the fire blazing. Don't be afraid of a raging fire. You have a fireplace that can take it. Besides, hot fires burn efficiently, burning off most of the volatile gases driven from the wood and minimizing the build-up of creosote in the chimney.

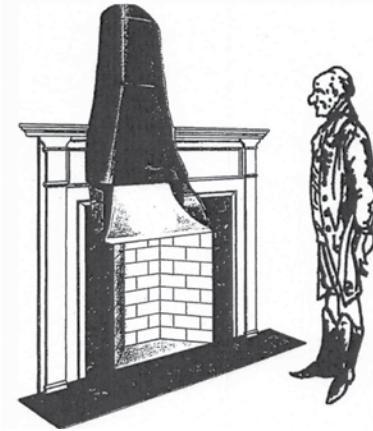

After a few minutes adjust the logs so the fire is stable, and add another log or two on end, leaning against the . fireback. The tall tepee style fire is surprisingly stable, falling in on itself as it burns, it rarely needs tending.

Enjoy! If you leave the room, put a good full screen in front of the fire, but if you 're paying any attention at all, it's much more cheery and warmer to enjoy the fire without a screen. You can adjust the heat of the fireplace by the wood you select. Fewer, larger logs will burn more slowly and put out less heat than the same amount of wood split smaller.

You're doing everything right if, after a few fires, the bottom half of the firebox has burned clean. There will be some smoke stains up higher where it's cooler but, if the firebricks near the fire are burned clean, it means your fires are hot enough. If not, check the quality of your wood and/or split it smaller. After each season you should clean the flue by running a special flue-cleaning brush through it several times. You should get only about a cup of soot out of the flue and know that it really didn't need cleaning. While you're at it, make sure the damper works properly. 100 years ago you would have whitewashed the firebox and put flowers in it for the summer.

SUPERIORCLAY.COM



P.O. Box 352 • Uhrichsville, OH 44683

800-848-6166